

EZ Tool Articulating Arm



Torque Arms

EZ tool arm features:

- Covers a 610 x 762 mm (24 x 30 inch) horizontal rectangular work envelope.
- Two piece arm with overall length adjustable from 864 to 1067 mm (34 to 42 inches).
- Anodized aluminum construction.
- Mounting plates attach vertically or horizontally.
- First portion of the arm consists of two adjustable sections connected to the mounting plate by a 360 degree pivot.
- Second, outer portion of the arm is a dual parallel arm design that allows for 500 mm (20 inches) of vertical travel, and is connected to the first portion by a 360 degree pivot.

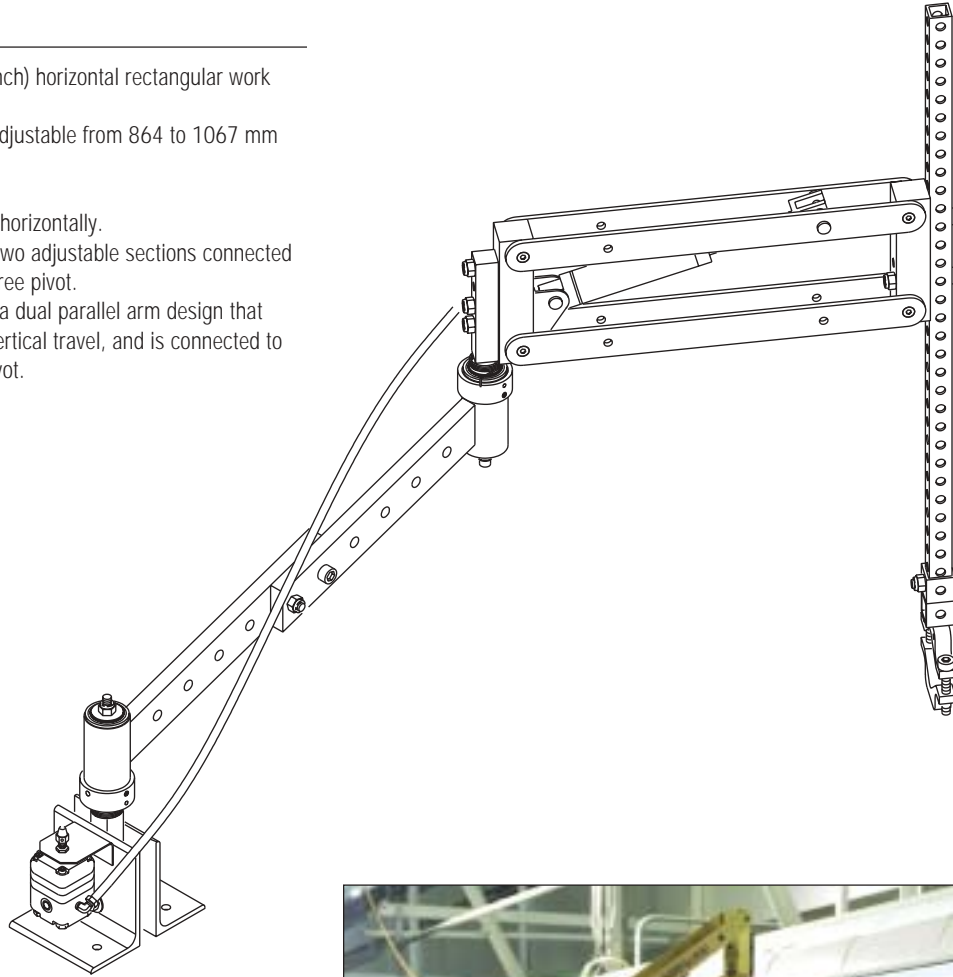

Additional features:

- Each pivot contains roller bearings for smooth operation and an adjustable pivot spring to return the arm to a "home" position.
- Capacity is 13.6 kg (30 lb) at 7 bar (100 psi).
- Pneumatics control system consists of a single precision pneumatic regulator to allow balance of the end of the arm. Maximum torque reaction is 80 Nm (60 ft/lb).
- Fixed tool holder to handle tool diameter from 13 to 63.5 mm (.50 to 2.5 inches) is adjustable for vertical or horizontal tool orientation.



EZ Tool Arm in an assembly process

EZ Tool Articulating Arm Specifications

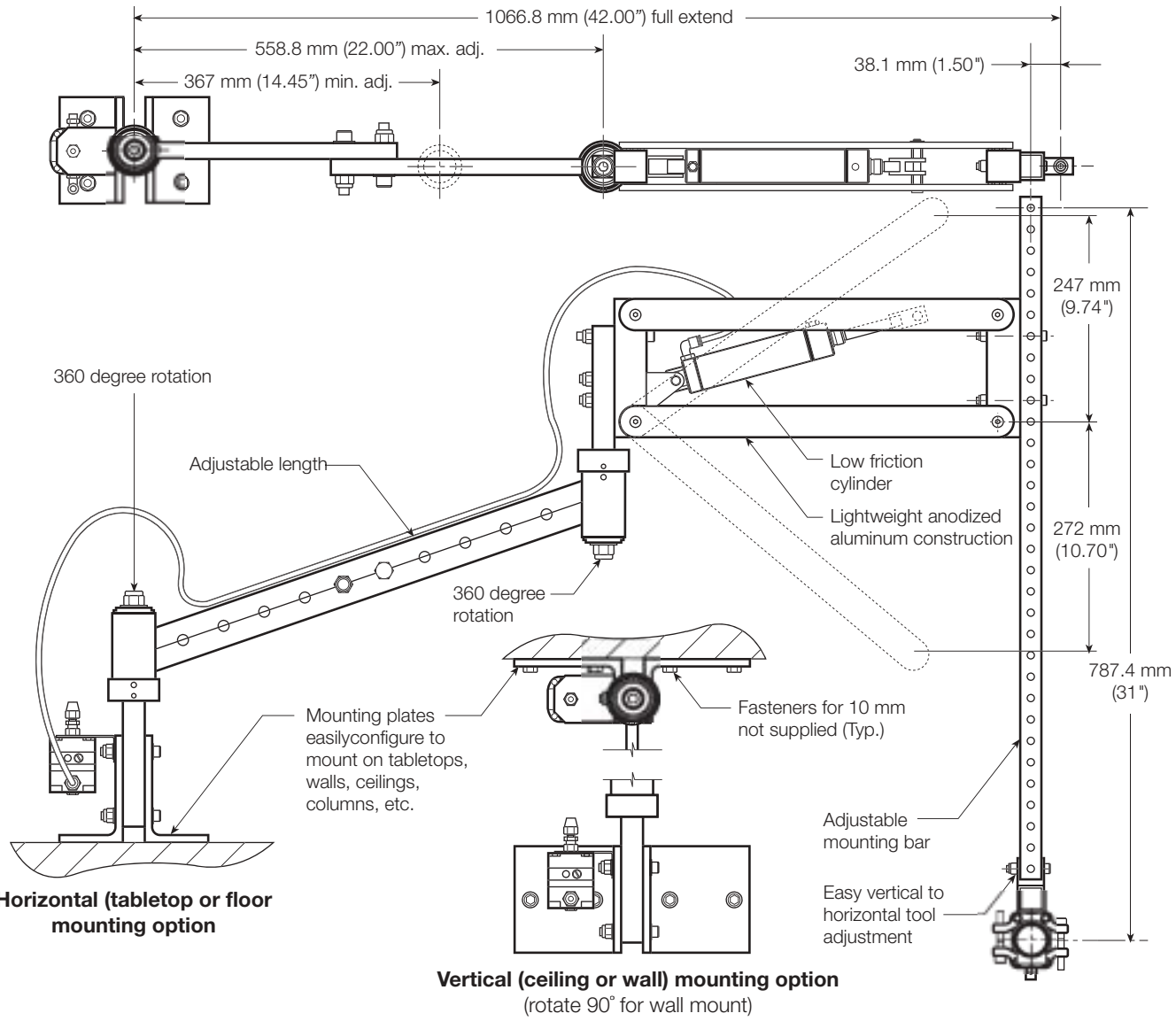

EZ tool arm model number EZTA080500 illustrated



Tool Holders

Part no.	Description
54033162	Bi-Directional tilt / Push to start tool
54033196	Single-Directional tilt tool holder

EZ Tool Arm

Part no.	Description
EZTA080500	Light weight torque arm with tool holder
43146000	Light weight articulating arm without tool holder

E-Z Torque



Torque Arms

Just as the name indicates, the new Ingersoll-Rand E-Z Torque® has taken the struggle out of using hand-held torque tools.

The lightweight E-Z Torque has been coupled with our 50 pound Balancer to provide the most innovative power tool assist system available today. Ease of operation eliminates operator fatigue problems, fights carpal tunnel syndrome and brings added safety to the workstation. E-Z Torque has been engineered to absorb the pounding reaction of air-powered or electric-driven torque tools. Constructed of cast aluminum and steel with ball bearing rollers and a 48 inch (1219.2 mm) vertical travel, the E-Z Torque eliminates spring pull back and maintains tool position with no problem.

Features:

- Lightweight torque tool assist
- Ease of operation
- Reduces operator fatigue
- Aluminum and steel construction
- Adjustable to fit any tool

E-Z Torque	
Part no. complete	Application
EZTQ5060	EZ Torque Tool Balancer
Suspension Kits	
16520	ZRA1 rail
16525	ZRA2 rail
16530	ZRS2/3 rail



E-Z Torque shown with optional tool

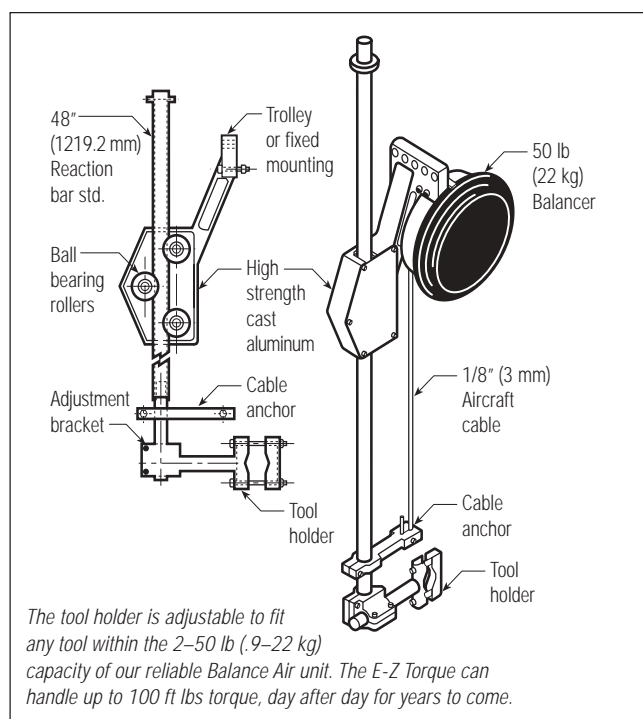

Ergonomic Torque Reaction Products

Torque Tube



Ingersoll-Rand is proud to introduce the world's first IRZ Series of Best-In-Class Ergonomic Torque Tube Products. The new IRZ series of products relieve the operator of tool weight and torque reaction, resulting in increased work place productivity. These products are designed to prevent the long-term damaging effects of torque reaction on the human body, resulting in lower workers compensation and health care costs.

The new IRZ Series Torque Tubes allow tools to be lifted, lowered, moved and brought into optimum working position with minimal force required by the operator. Whether the products are used alone or integrated into a larger "turnkey" system, the smooth and effortless vertical motion will be the perfect solution for assembly applications. The availability of various sizes and the modularity of design provides System Integrators and Tool Builders the flexibility they need, to offer assembly solutions to customers.

Torque Tube Features

- Available in 3 torque capacities: 100 Nm, 250 Nm, and 500 Nm
- Modular worldwide metric design
- Super linear bearings for effortless vertical travel and maintenance free operation
- 60 lb, 60 lb and 400 lb capacities
- 4 Delrin wheels for torque reaction and side loading in all four directions
- Adjustable lengths (every 2 inches/ 50.8 mm) to eliminate the need for extension tubes
- All bolt on assemblies (Tool Holders and Suspension)
- Lightweight construction

Tool Holder Features

- Tool holder clamp is 316 stainless steel construction designed to minimize tool damage
 - Accepts tools of 19 mm to 63 mm/.75 to 2.5 in. diameter
 - Switches easily from horizontal to vertical orientation
- 360 degree tool holder features:**
- Generous 66.8 mm/2.63 in. opening insures that tool head does not have to be removed for quick changes
 - Bronze bushing provides easy rotation and durability
 - Rotates freely through 360 degrees or locks at 45 degree increments with indexing plunger
- Fixed tool holder**
- Fixed tool holder accepts tools of 13 to 63 mm (.50 to 2.5 inch) diameter
 - Tool holder easily changes from horizontal to vertical
 - Custom tool holders available

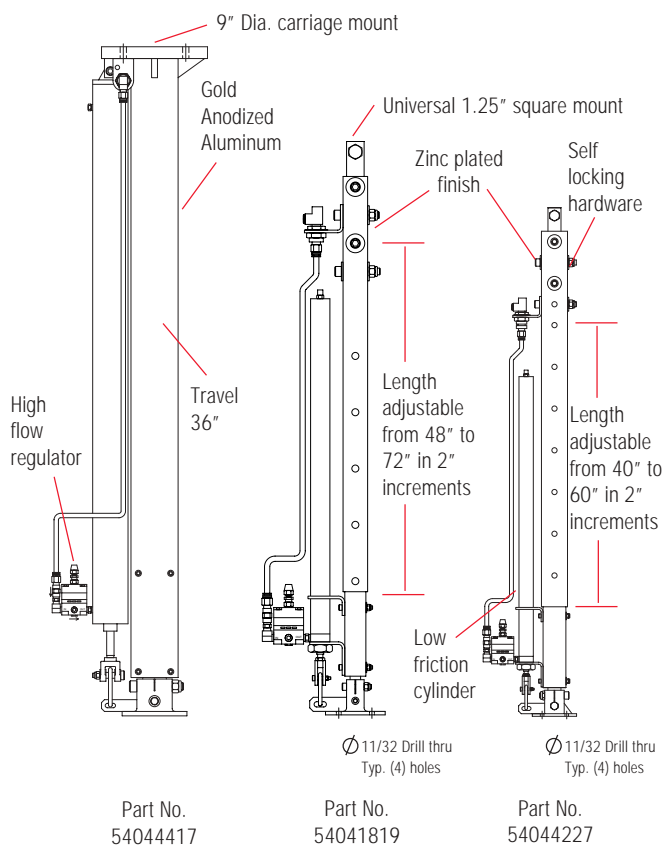

Tool Holders for IRZ-TT-100 and IRZ-TT-250

Part No.	Description	"D" Dimension		Weight	
		in.	mm	lbs	kg
52000	Fixed (2 axis) horiz./vertical	4.82	122	2.30	.90
52100	360 degree (3 axis) swivel	5.38	136.7	5.00	2.27

Note: IRZ-TT-500 requires custom tool holder

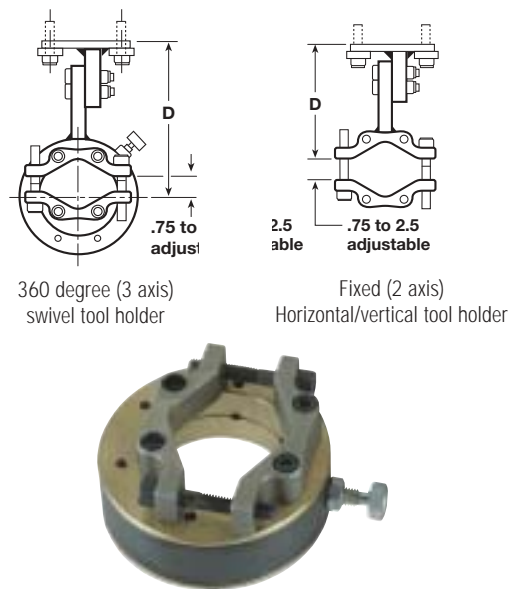

Torque Tube

Part No.	Description	Torque Capacity		Lift Capacity		Weight		Travel	
		ft-lbs	Nm	lbs @ 100 psi	lbs @ 7 kg/cm ²	lbs	kg	in.	mm
54044227	IRZ-TT-100	74	100	60	27	40	18	20	508
54041819	IRZ-TT-250	184	250	60	27	50	23	24	610
54044417 ^{1,2}	IRZ-TT-500	368	500	400	182	75	75	36	914

Air cylinder and regulator are included in these part numbers.

(1) Carriage mount option only.
 (2) Custom tool holder required - contact factory.



Suspension Kits – Single and Dual Trolleys

Model No.	Part No.	"A" Dimension in.	mm	Weight lbs	kg
Dual Trolley⁽¹⁾					
Single – Use for 80nm or less applications					
ZRA2	16610	4.75	120	4.50	2
ZRAS2/3	16600	4.75	120	4.50	2
KBK-II/III	16615	4.75	120	4.50	2
ETA-8	16635	4.75	120	4.50	2
T-Rail	16620	3	76.2	15	6.8
Dual – Up to 150nm applications					
ZRAT	16755	6.48	165.0	10.50	4.76
ZRA1	16705	6.13	156.0	10.50	4.76
ZRA2	16710	6.76	172.0	10.50	4.76
ZRAS2/3	16700	6.76	172.0	10.50	4.76
KBK-I	16725	6.13	156.0	10.50	4.76
KBK-II/III	16715	6.76	172.0	10.50	4.76
ETA-4	16744	6.13	156.0	10.50	4.76
ETA-8	16735	6.76	172.0	10.50	4.76
Gorbel	16707	6.13	156.0	10.50	4.76

Note: For use on torque tube part no. 54044227 and 54041819.

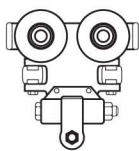

Suspension kit, Single trolley
Use for 80nm or less

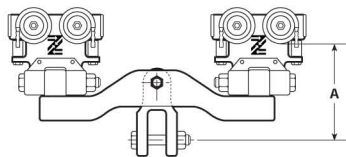

Suspension kit, Dual trolley
Use for 150nm or less

DISTRIBUTOR:

KAVON CZ s.r.o.

Pardubice
Mikulovická 2642, 530 02 Pardubice
tel.: 466 797 511 • fax.: 466 797 520
email: info@kavon.cz • www.kavon.cz

Mladá Boleslav
Staré Město 85, 293 01 Mladá Boleslav
tel.: 326 329 727 • tel.: 736 753 975
email: kavon.mb@wo.cz



Brno
Hviezdoslavova 55, 627 00 Brno - Slatina
tel.: 548 213 068 • tel.: 603 893 537
email: kavon.brno@wo.cz

Praha
Jinonická 329, 158 00 Praha
tel.: 251 045 101-2 • tel.: 603 848 716
email: kavon.pha@wo.cz

Cylinder Air Supply

Part No.	Description
90050	Cylinder air supply package

Includes regulator assembly and all required hose fittings to supply cylinder.

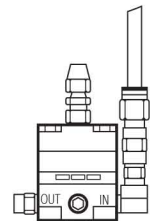

Air Cylinders

Part No.	Vertical Travel in.	mm
54044342	20	508
54041751	24	610
54044516	36	914

Carriages

**	Description	Part No.
NT	Carriage-Basic, no trolleys	40710
TR	Carriage Assembly - T-Rail / I-Beam	40709
A2	Carriage Assembly - ZRA2 (reaction trolley)	30028-1
S2	Carriage Assembly - ZRS2 / ZRS3	30028-2
A1	Carriage Assembly - ZRA1	30028-3
E8	Carriage Assembly - ETA-8 (reaction trolley)	30028-4
K2	Carriage Assembly - KBK2	30028-5

Note: For use on part no. 54044417
Lightweight ALMAG casting. Basic carriage weighs 60.0 lbs (27.3 kg)
Each Carriage Ass'y drawing has info for both Hi & Low Profile Assemblies.

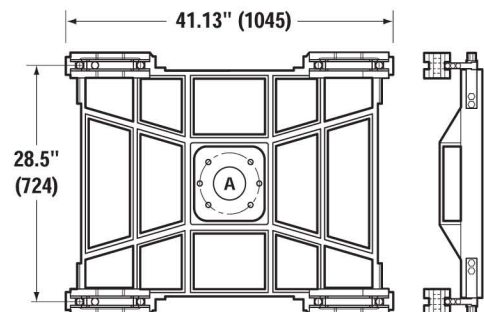

- A = 1/2" bolts (6), Holes on a 7.5" bolt circle as shown
- 9/16" drill thru on a 7.5" bolt circle.
- B = 27.25"
- C = 37.5"